

# User's Manual

## for CS36A12V2



Bundled Kit  
(CA50A48V2 + CS36D12V)

### IMPORTANT SAFETY WARNINGS (SAVE THESE INSTRUCTIONS)

This manual contains important instructions regarding the installation and operation of this device. Read this manual thoroughly before attempting to unpack, install or operate this device.

**CAUTION!** To prevent the risk of fire or electric shock, install in a temperature and humidity controlled indoor area free of conductive contaminants. (Please see specifications for acceptable temperature and humidity range.)

**CAUTION!** To reduce the risk of electric shock, do not remove the cover except to service the battery. No user serviceable parts are inside except the battery.

**CAUTION!** Risk of explosion if battery is replaced by an incorrect type. Dispose of used batteries according to the instructions.

**CAUTION!** This unit must be wall mounted. Do not use the unit unless it is mounted correctly.

### OVERVIEW (CS36D12V)

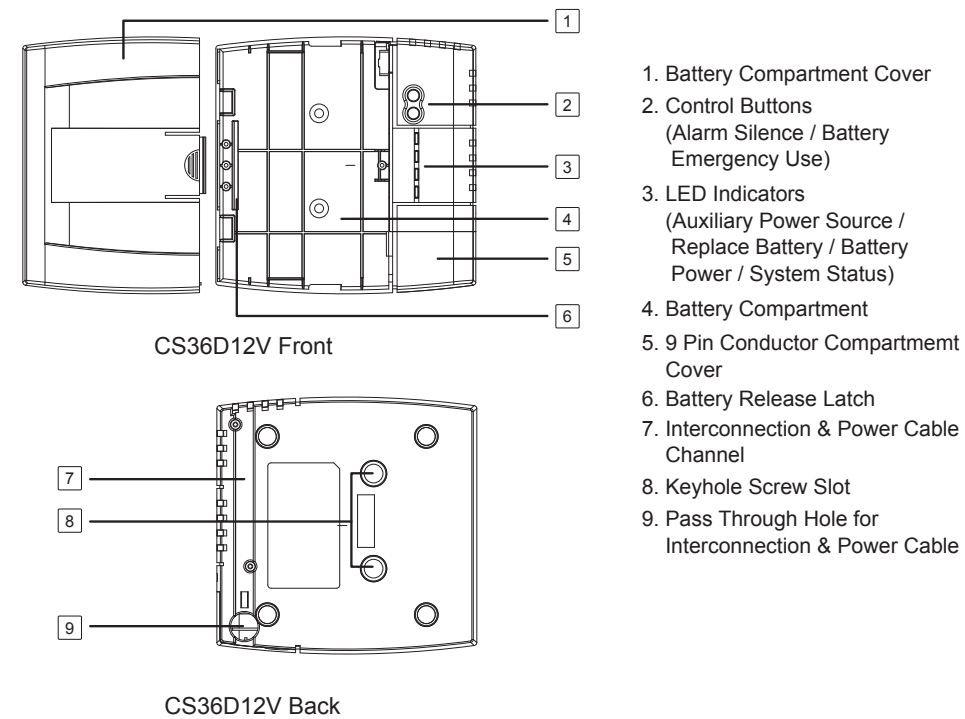

1. Battery Compartment Cover
2. Control Buttons (Alarm Silence / Battery Emergency Use)
3. LED Indicators (Auxiliary Power Source / Replace Battery / Battery Power / System Status)
4. Battery Compartment
5. 9 Pin Conductor Compartment Cover
6. Battery Release Latch
7. Interconnection & Power Cable Channel
8. Keyhole Screw Slot
9. Pass Through Hole for Interconnection & Power Cable

### CA50A48V2 Installation Guide

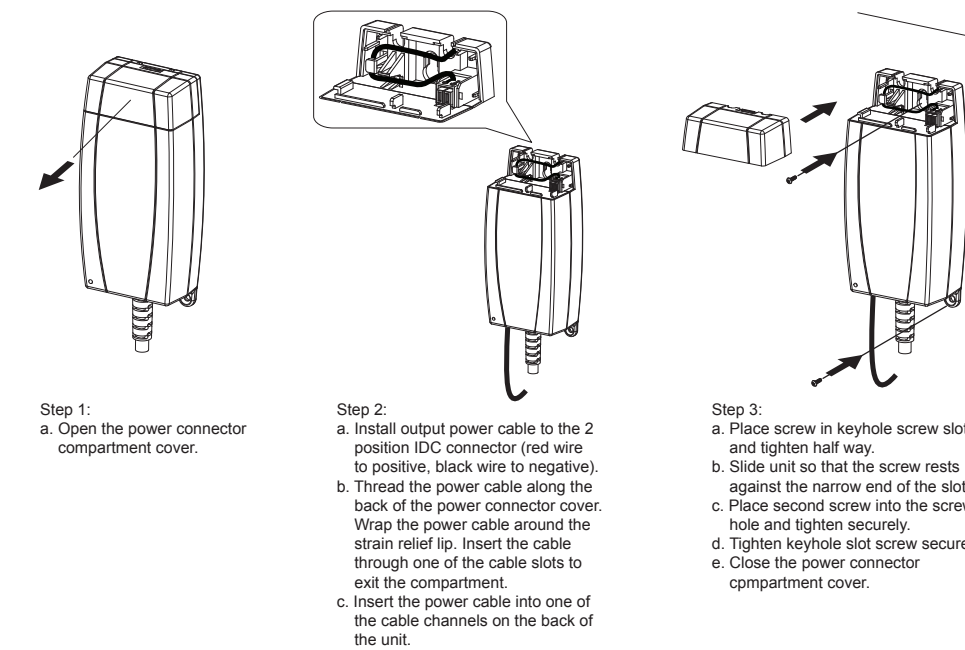

**NOTE:** Please use appropriate size screws to mount the CA50A48V2 on the wall.  
**NOTE:** Recommended screw size: Self-tapping screw M4x20L (Truss head)

### CS36D12V Installation Guide

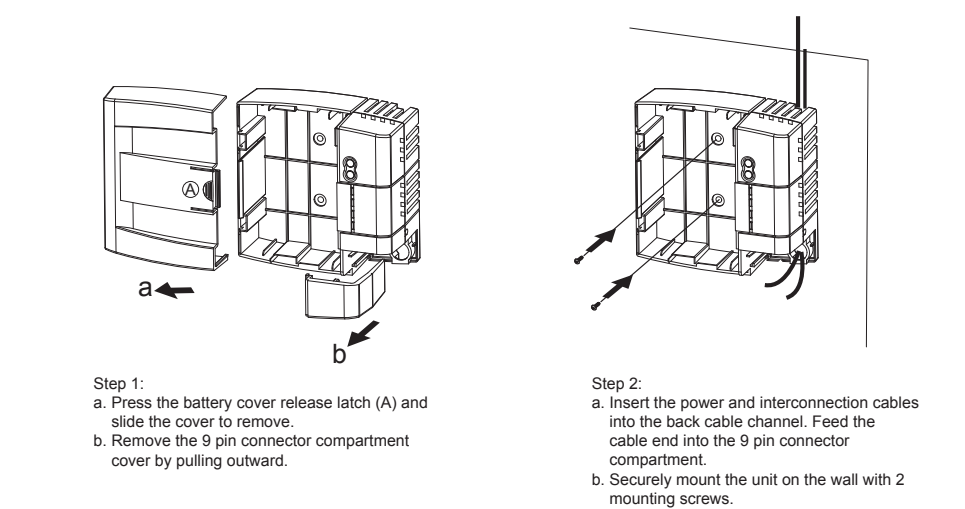

**NOTE:** Please use appropriate size screws to mount the CS36D12V on the wall.  
**NOTE:** Recommended screw size: Self-tapping screw M4x20L (Truss head)

### INTRODUCTION

The CS36A12V2 provides increased flexibility and cost effectiveness by separating the power supply unit (CA50A48V2) from the battery back up unit (CS36D12V). The power supply plugs into a 110/120Vac outlet. It converts the power to 48Vdc, which is then fed through a power cord to the battery back up unit. The battery back up unit feeds 12Vdc to the ONT.

### SYSTEM BLOCK DIAGRAM

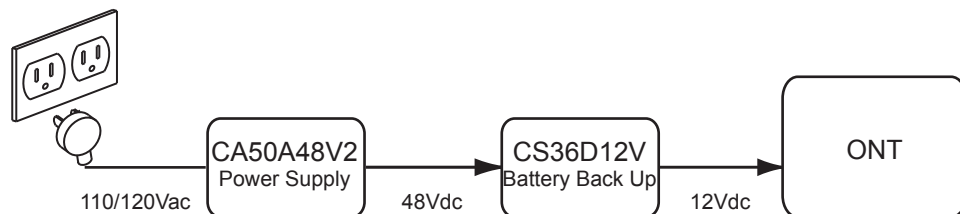

### INSTALLATION

- Carefully follow these instructions during the installation of this device:
- 1.) Carry out the installation in a safe area that is free of excessive dust and has adequate airflow.
  - 2.) Screws must be appropriate for total weight of the UPS unit and the mounting surface material.
  - 3.) Do not operate the UPS where the temperature and humidity are outside the specified limits. (Refer to specifications in this manual.)

### OVERVIEW (CA50A48V2)

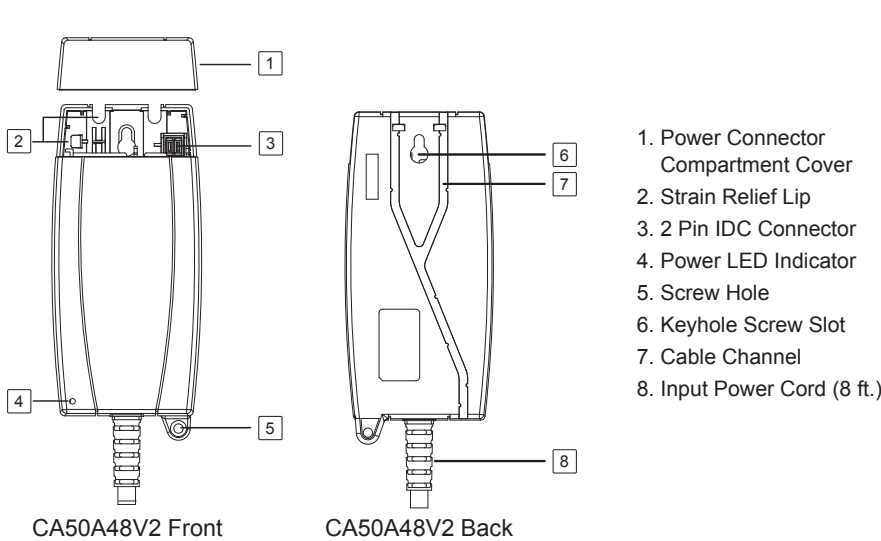

1. Power Connector Compartment Cover
2. Strain Relief Lip
3. 2 Pin IDC Connector
4. Power LED Indicator
5. Screw Hole
6. Keyhole Screw Slot
7. Cable Channel
8. Input Power Cord (8 ft.)

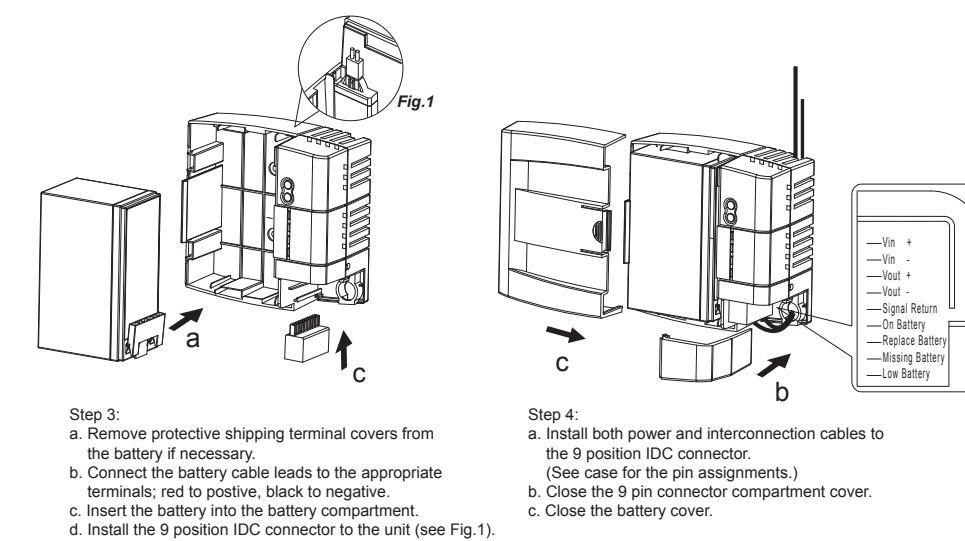

**!** The UPS battery charges when it is connected to utility power. The battery charges fully during the first **24 hours** of normal operation. Do not expect full battery run capability during this initial charge period.

### Operation Guide

**Start-Up:** Plug the CA50A48V2 power supply into AC power. The unit is now ready to be placed into service. The CS36D12V has four LED indicators and two control buttons. The table below lists the functions of each.

### LED Indicators

Indicator	Color	Condition
Alarm Silence Button	Blue	Press and hold the button for 1 second to silence the audible alarm.
Battery Emergency Use Button	Blue	Press and hold the button to activate emergency battery capacity.
Auxiliary Power Source	Green	Indicates that an external power source with adequate voltage (12Vdc) is connected to the CS36D12V.
Replace Battery	Red	Battery replacement required. Alarm will beep once every 15 minutes.
Battery Power	Green	Indicates the battery is supplying the power. At 45% battery capacity, this LED will flash and then alarm will beep 4 times per minute.
System Status	Green	Indicates normal mode of operation.

### Status LED, Alarm & Communication Signals

Condition	Status LED	Alarm	Interface	Description
Normal	System LED On		All communication signals in Low state	Condition normal; AC power load, charges battery. Battery is connected and in good condition.
ON Battery	Battery LED On		Open	48V input failure or loose connection between power supply and battery board; battery is supplying the power.
Replace Battery	Replace Battery LED On	1/2 sec beep every 15 min	Open	Every 45 days, the unit will automatically initiate a battery test. The test lasts 16 hours. If the battery needs to be replaced, an alarm signal will be sent to the Central Office.
Battery Missing		None, only ON sees alarm	Open	Approximately 6 seconds after battery removal, the system initiates battery detection routine. Upon failure, an alarm signal will be sent.
Low Battery	Battery LED Flash	1/2 sec beep every 15 sec	Open	When battery capacity is < 45% (approximately 12Vdc), unit signals low battery.

### Battery Type

The battery is a standard sealed lead acid battery rated at 12Vdc / 7.2Ah. If required, the battery may be replaced with an approved 12Vdc / 7Ah battery.

**!** Batteries are considered HAZARDOUS WASTE and must be disposed of properly. Most retailers that sell batteries collect used batteries for recycling.  
Pb

### Auxiliary Power Connection (AUX)

Connection point for customer-supplied DC input voltage (12Vdc). At 45% remaining capacity, the CS36D12V switches from internal battery to external source. The auxiliary power source supplies power to the load (ONT) in the event of 48V input voltage failure and a battery capacity of <45%.

### Maintenance Mode

Maintenance mode determines remaining useful battery life. During the 16 hour test, the battery is discharge to determine its state. The unit measures the rate of change in the battery charge. If the rate of discharge is excessive, the battery replacement indicator is activated.

- The CS36D12V enters the maintenance mode approximately once every 45 days.
- In the event that the CS36D12V is in the maintenance mode and an AC failure occurs, maintenance mode will cease and the CS36D12V will supply the power to the load.

### FCC NOTICE:

This equipment has been tested and found to comply with the limit for a Class B digital device, pursuant to part 15 of the FCC Rules. These limits are designed to provide protection against harmful interference in a residential installation. This equipment generates, uses and can radiate radio frequency energy and, if not installed and used in accordance with these instructions, may cause harmful interference to radio communications. However, there is no guarantee that interference will not occur in a particular installation. If this equipment does cause harmful interference to radio or television reception, which can be determined by turning the equipment off and on, the user is encouraged to try to correct the interference by one or more of the following measures: (1) Reorient or relocate the receiving antenna. (2) Increase the separation between the equipment and receiver. (3) Connect the equipment into an outlet on a circuit different from that to which the receiver is connected. (4) Consult the dealer or an experienced radio/TV technician for help.

**CAUTION:** Signal cables must be used with this device to ensure compliance with Class B FCC limits.  
**CAUTION:** Any changes or modifications could void the authority granted by the FCC to operate this equipment.

### CS36D12V Battery Replacement

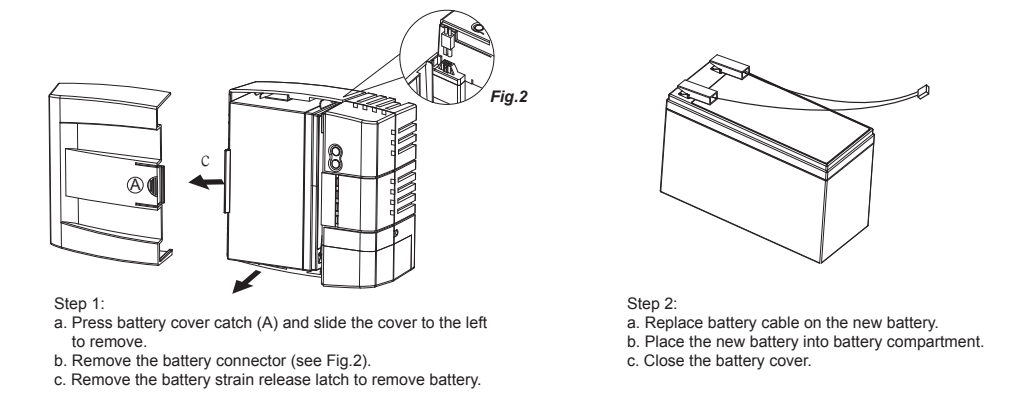

### Specification

Model	CA50A48V2	CS36D12V
<b>Input</b>		
Voltage Range	120Vac	48Vdc
Frequency Range	50 / 60Hz	
<b>Output</b>		
Output Voltage (Normal)	48Vdc	12Vdc
Output Voltage (Battery Mode)		10.5 ~ 20Vdc
Output Power Max	48W	34W
Ripple	less than 200 mV	
Connector Type	Insulation Displacement Connector (IDC)	
<b>Battery</b>		
Battery Type	Sealed, Maintenance Free Lead-Acid Battery	
Numbers of Battery	7.2Ah / 12V	
Auxiliary Input Power	12Vdc / 1.3mm COAX Power Jack	
<b>Warning Diagnostics</b>		
Indicators	AC Power	Auxiliary Power Source / Replace Battery / Battery / System
Alarm		AC Fail / Replace Battery / Replace Battery / Low Battery
<b>Management</b>		
Communication Interface		Signal Return / On Battery / Replace Battery / Missing Battery / Low Battery
<b>Physical</b>		
Maximum Dimensions (L*W*D)	5.94 x 2.65 x 1.56 in	6.89 x 6.75 x 3.47 in
Weight (lb)	0.77lb	1.51lb
<b>Environment</b>		
Operating Temperature	-4°F ~ +115°F (-20°C ~ +46°C)	
Operating Humidity	0 - 95% noncondensing within enclosure	
Max Operating Elevation	10,000ft (3,000m)	
Max Storage Elevation	50,000ft (15,000m)	
Storage Temperature	-4°F ~ +113°F (-20°C ~ +45°C)	